

AIR CONDITIONING UNIT PIPING

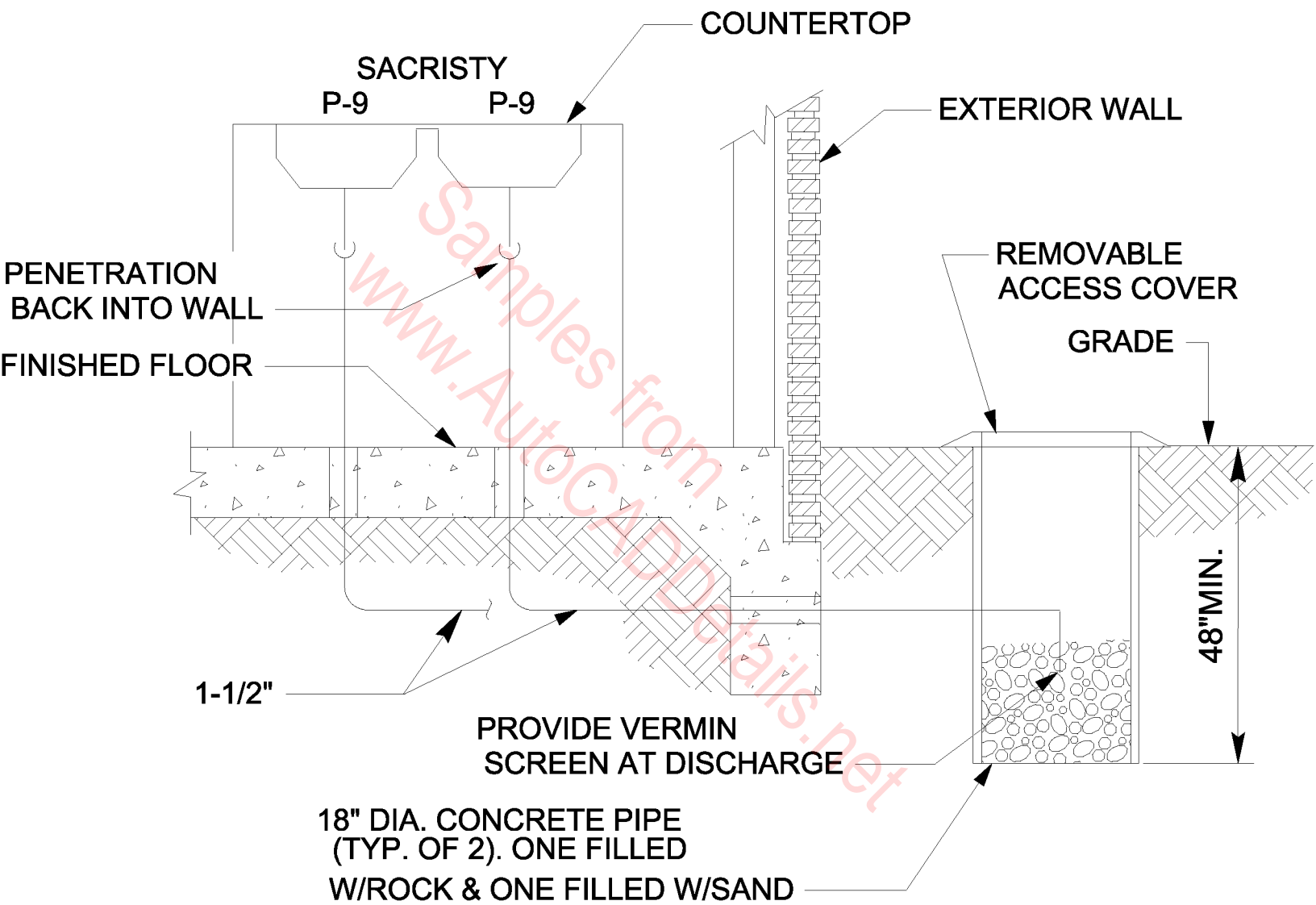

DRY SUMP DETAIL

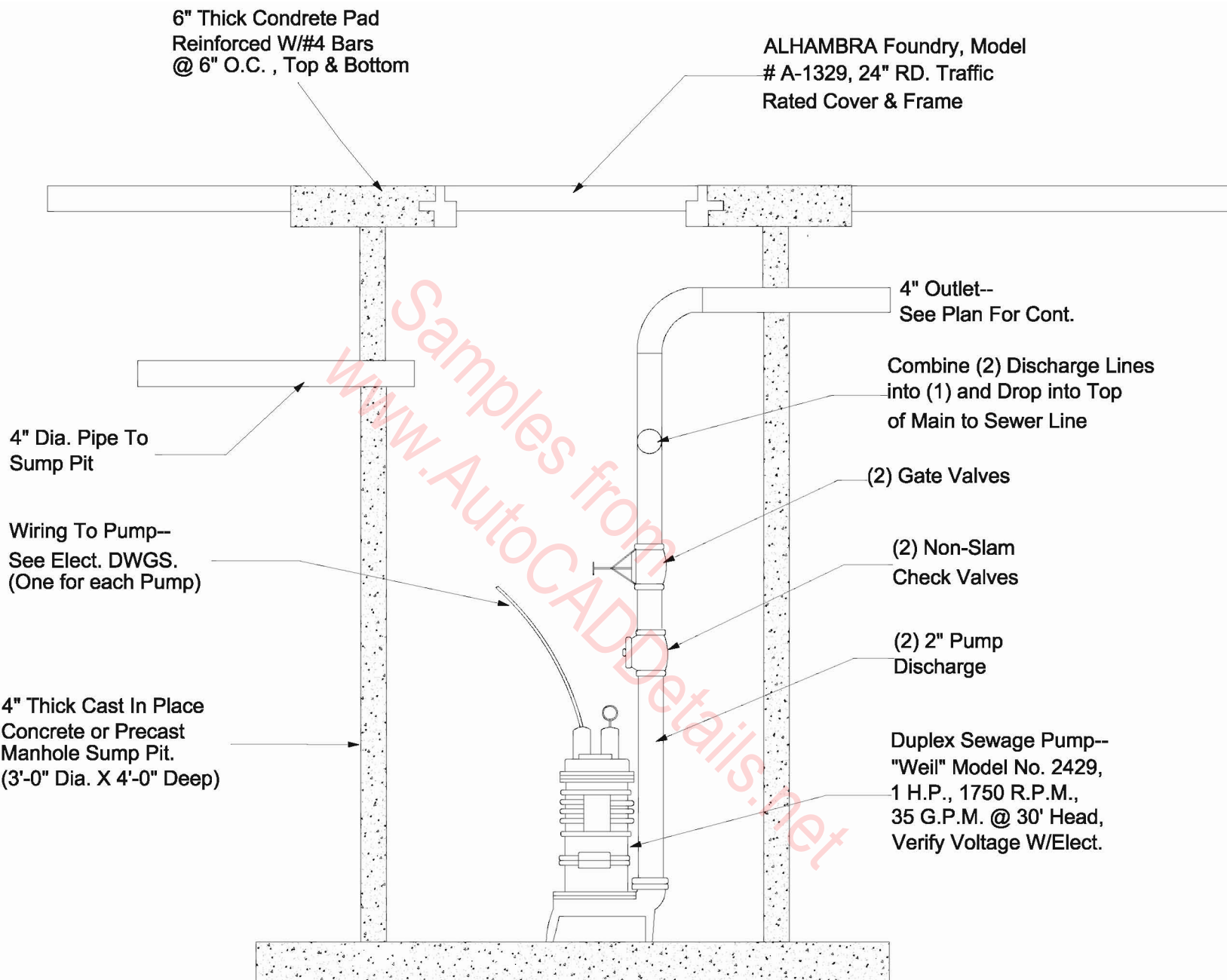

NOTE:
 SUMP INTERIOR FOR SEDIMENT AND PUMP
 SHALL BE LINED WITH WATERPROOF COATING

DUPLEX SEWAGE EJECTOR DETAIL

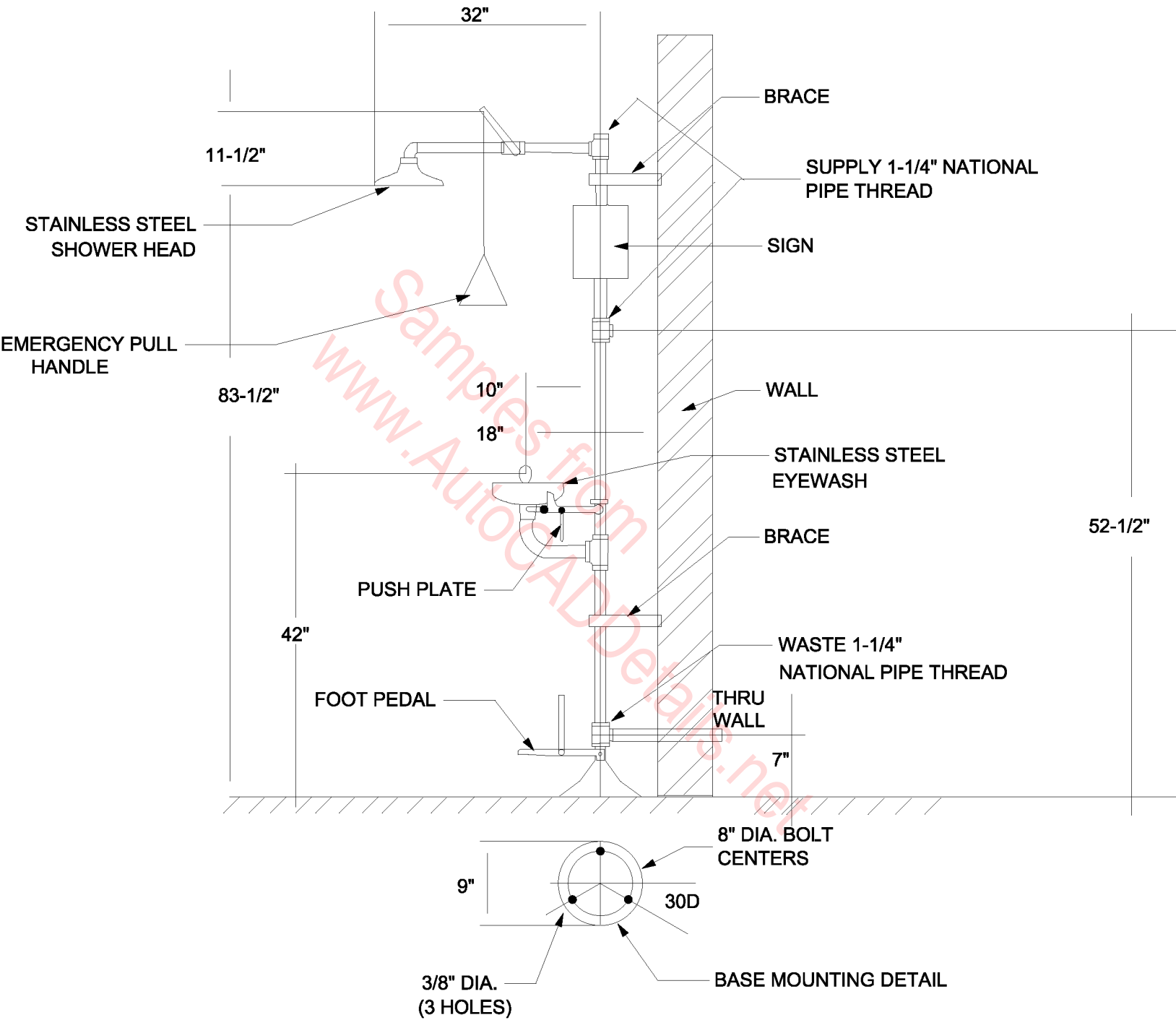

EMERGENCY EYEWASH DETAIL

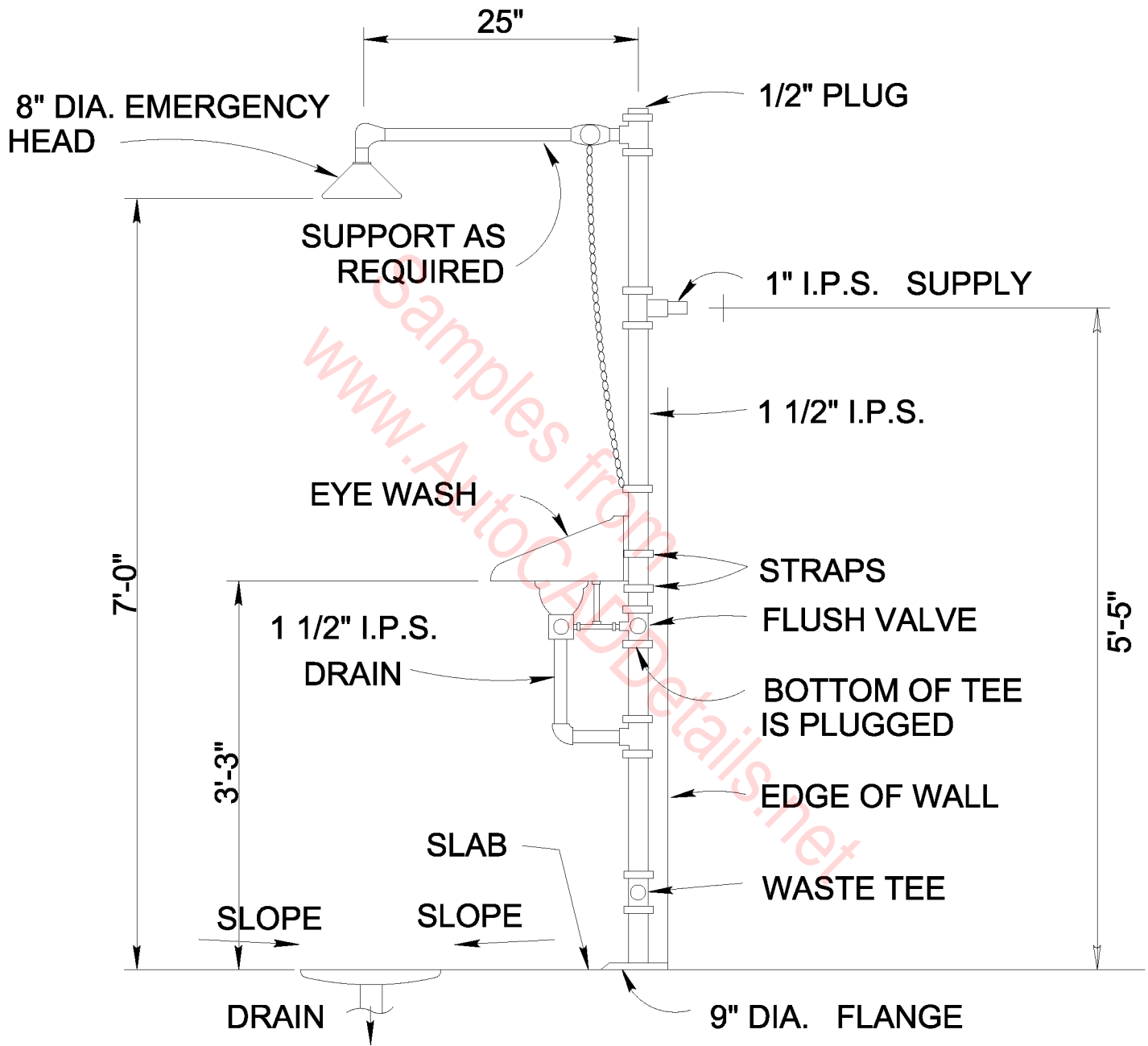

EMERGENCY SHOWER & EYE WASH DETAIL

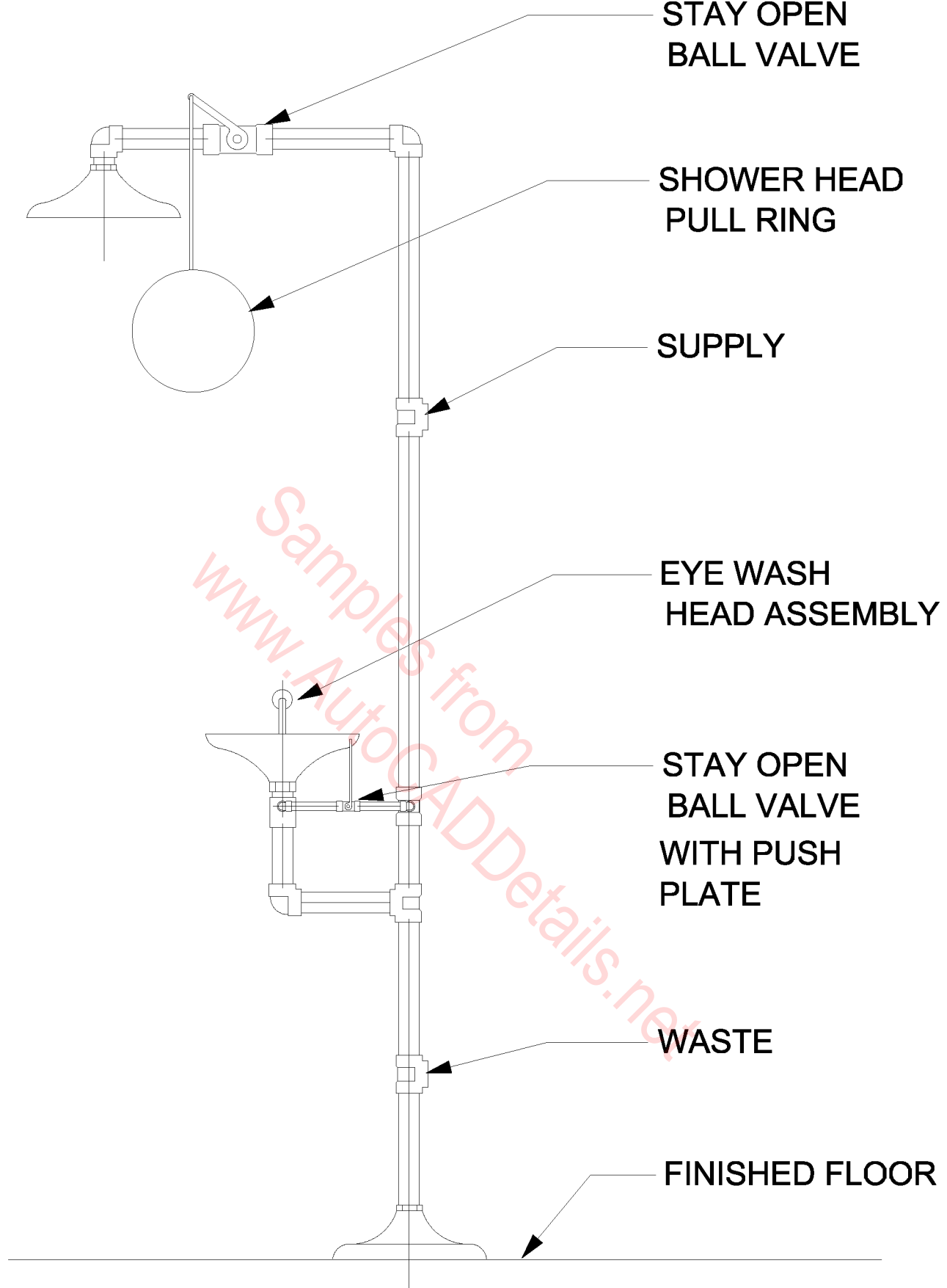

EMERGENCY SHOWER

WITH EYE WASH

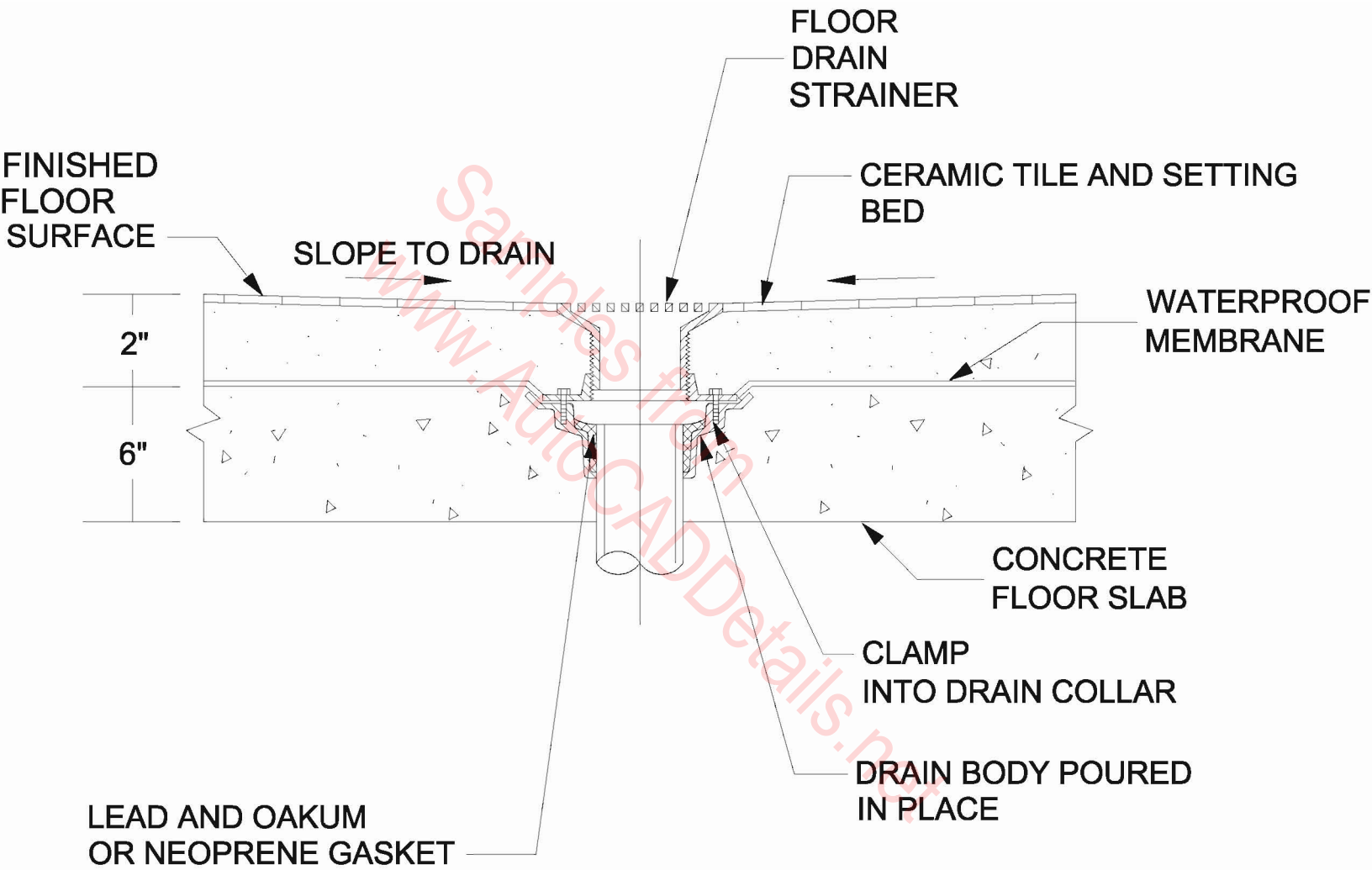

FLOOR DRAIN IN OPEN AREA

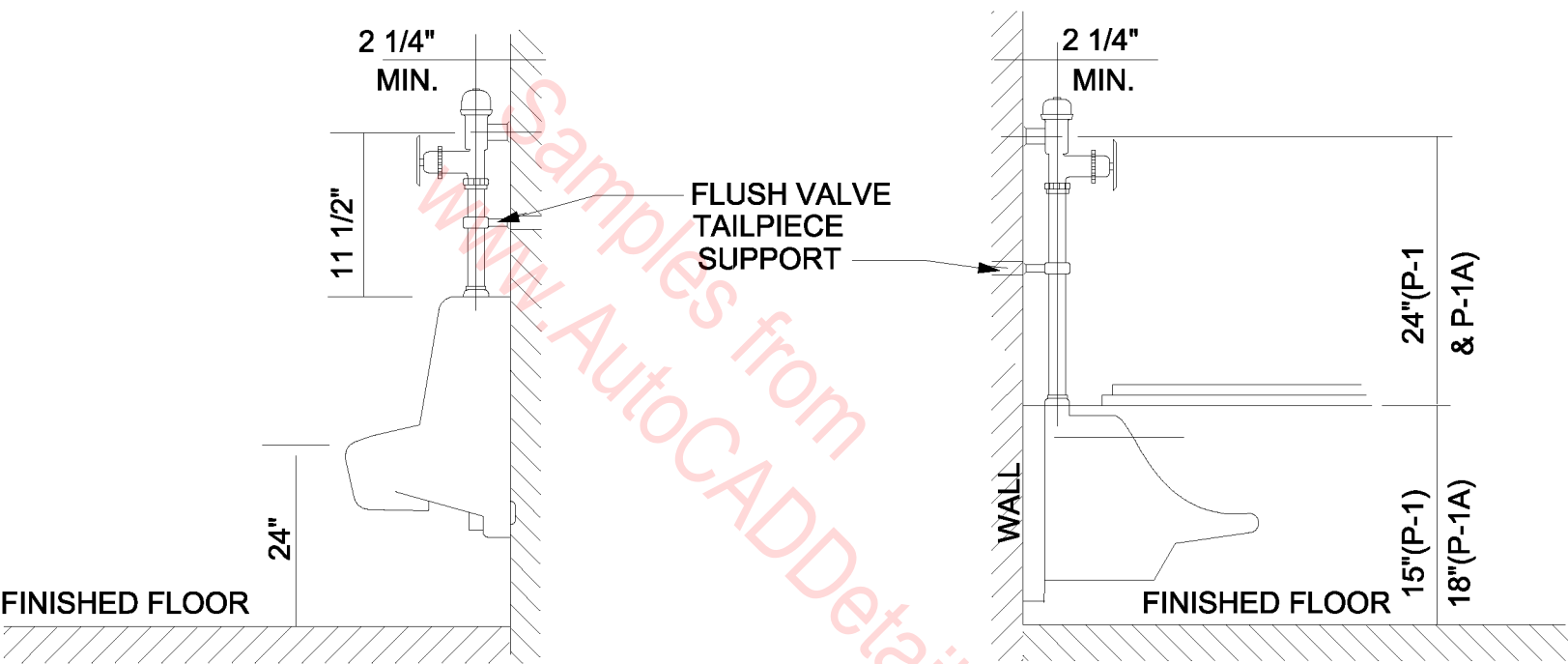

FLUSH VALVE SUPPORT DETAIL

N.T.S.

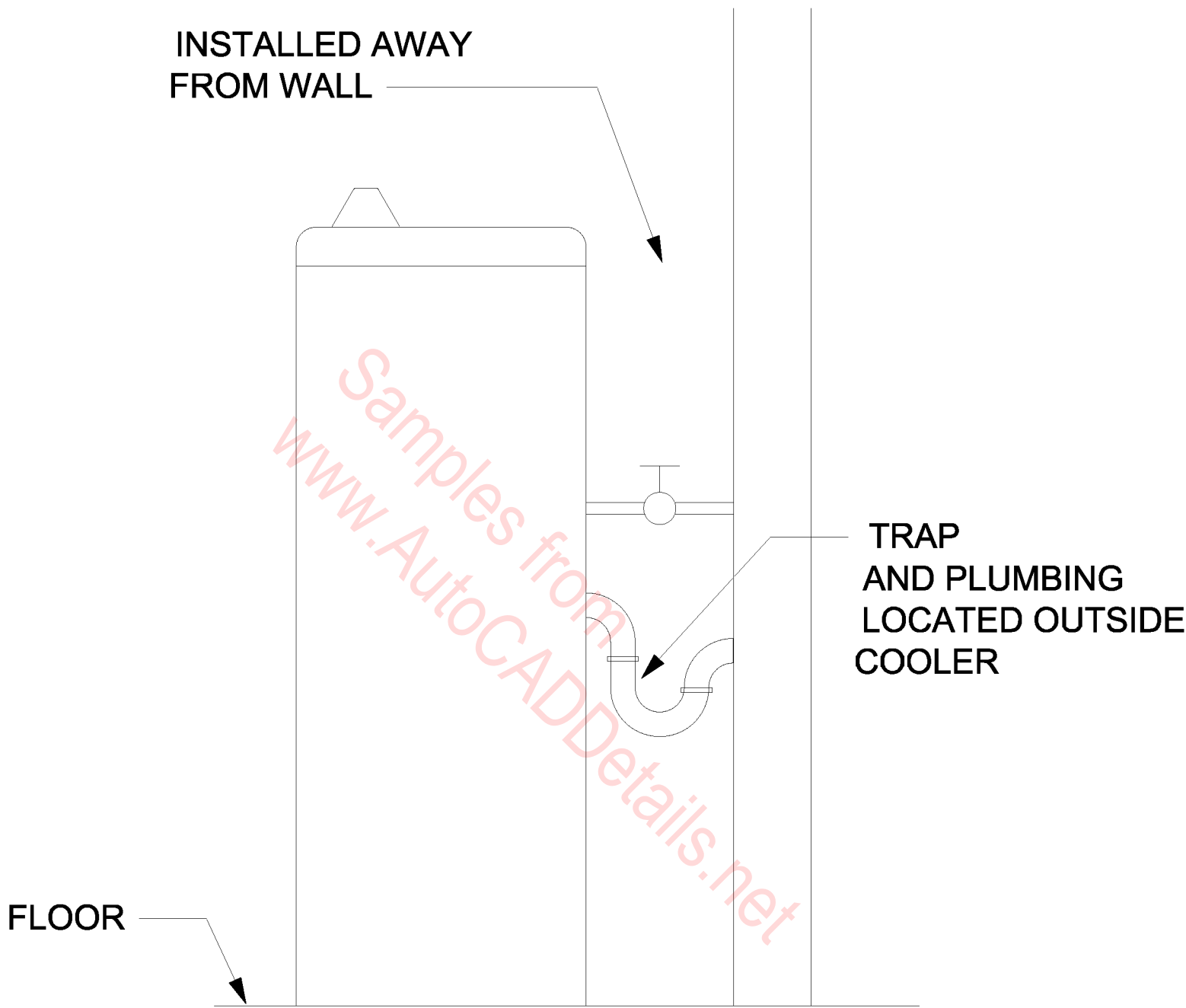

NOTES:

1. INSTALL ACCORDING TO MANUFACTURER'S INSTRUCTIONS.

FREE STANDING DRINKING WATER COOLER

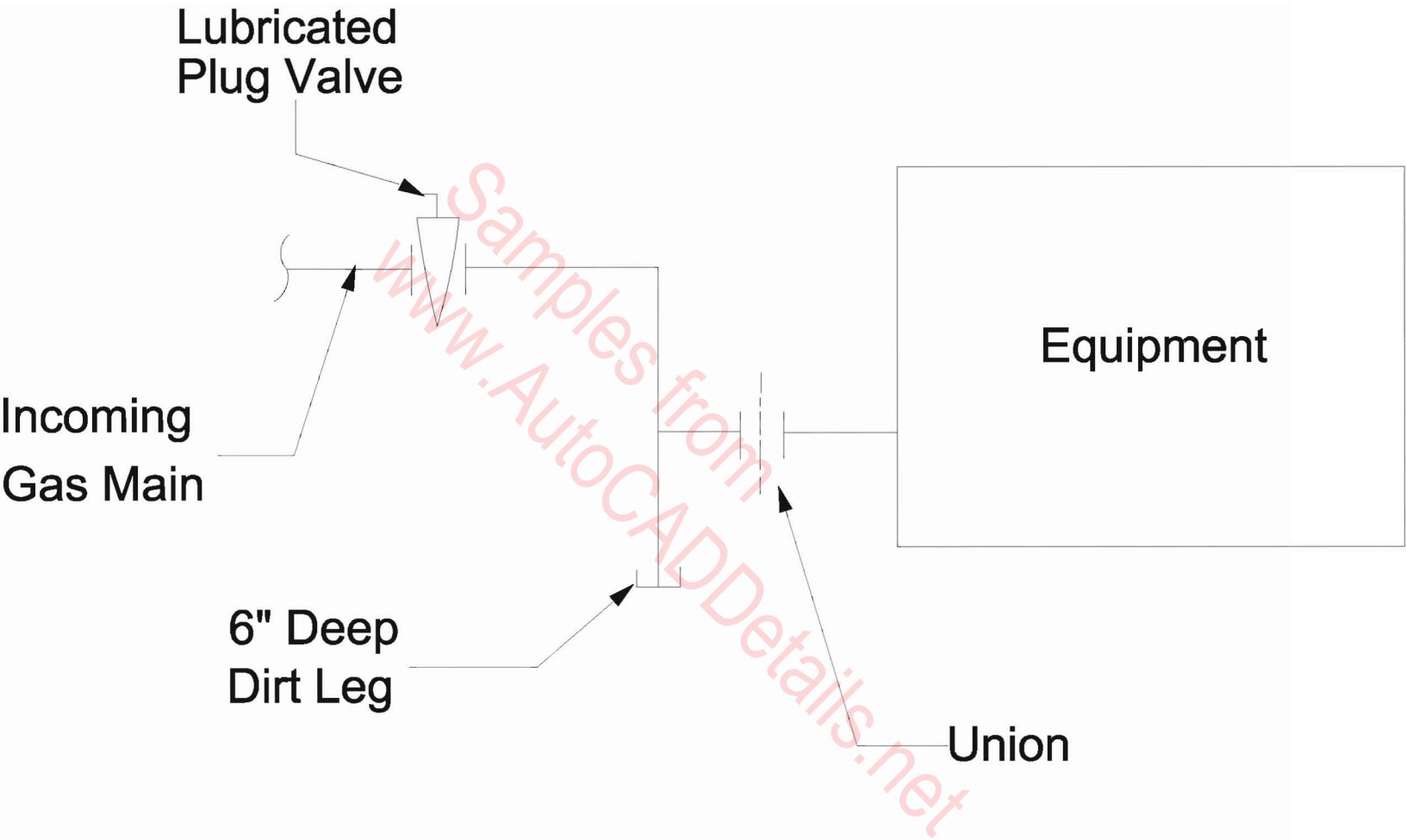

Gas Equipment Connection

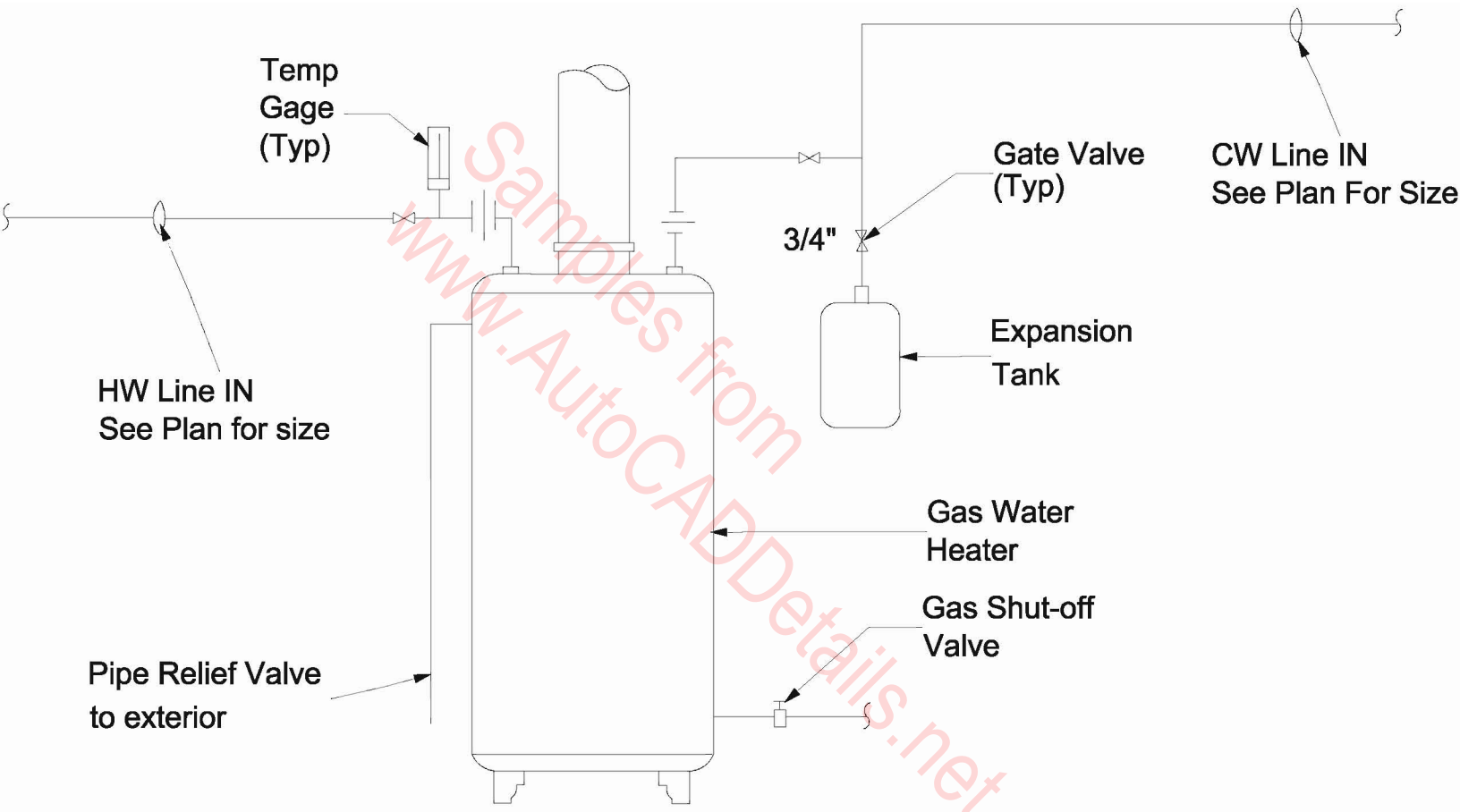

Gas Fired Water Heater

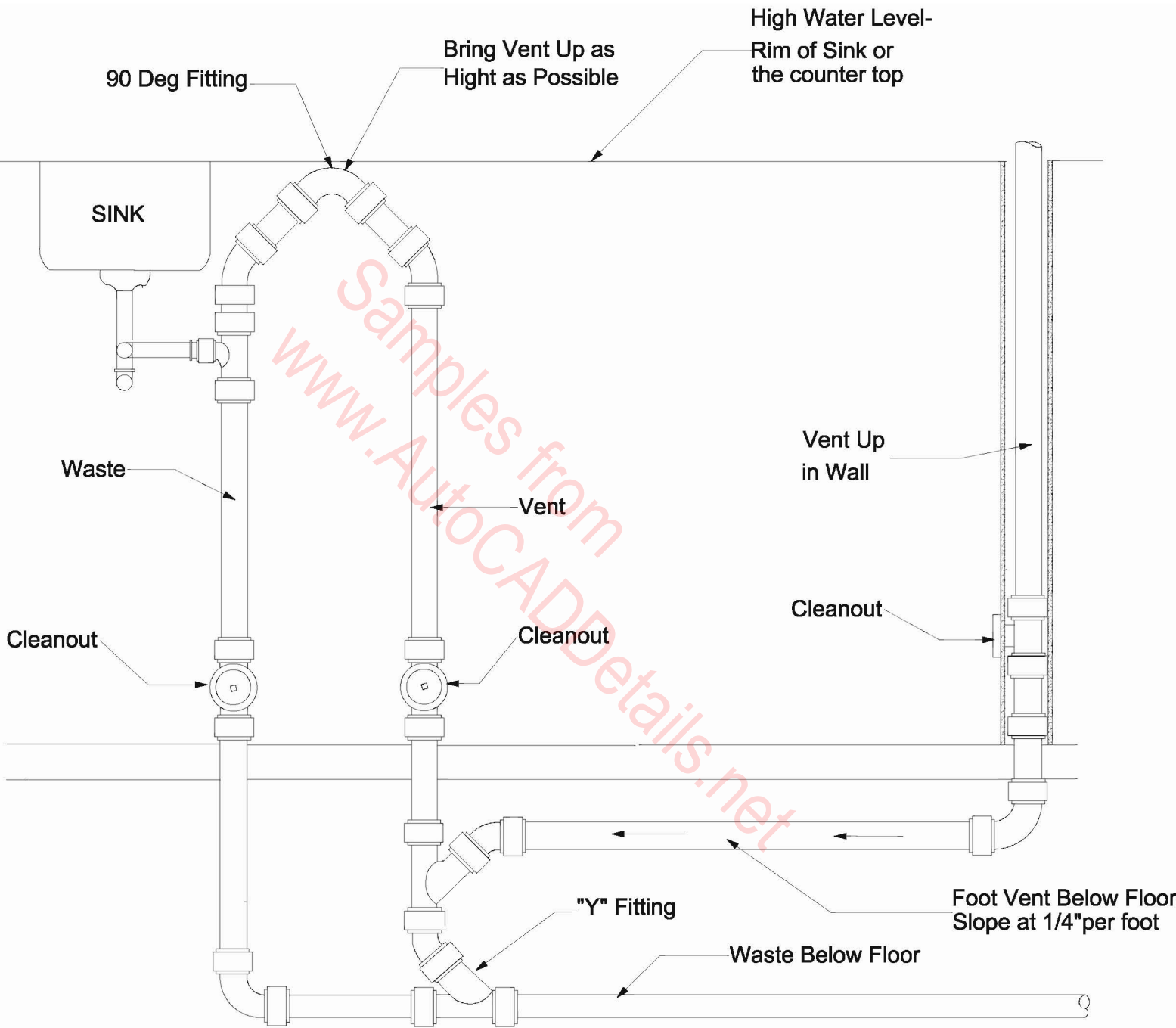

ISLAND VENT DETAIL

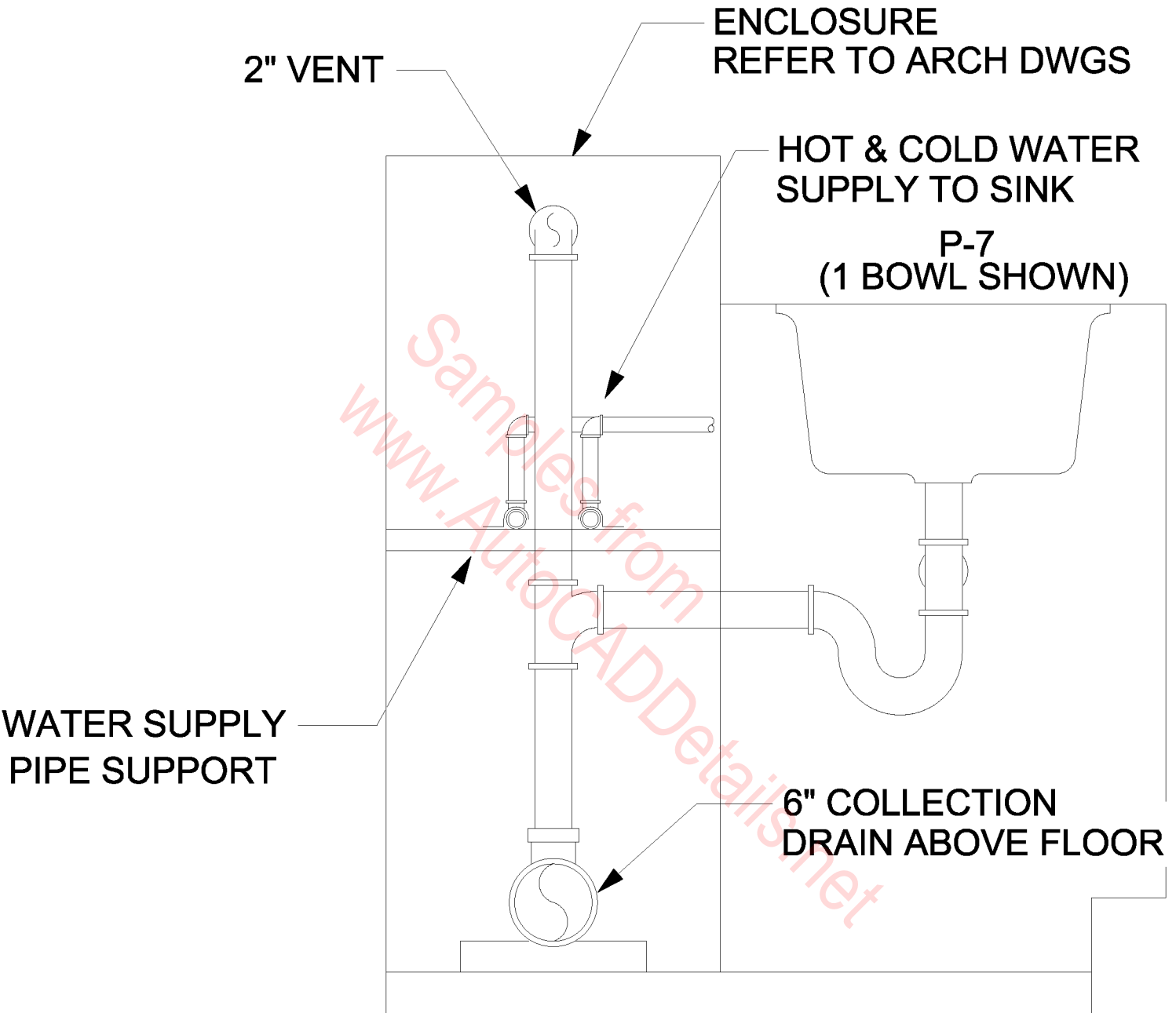

DOUBLE BOWL TYPE

LAUNDRY SINK DRAIN CONNECTION DETAIL

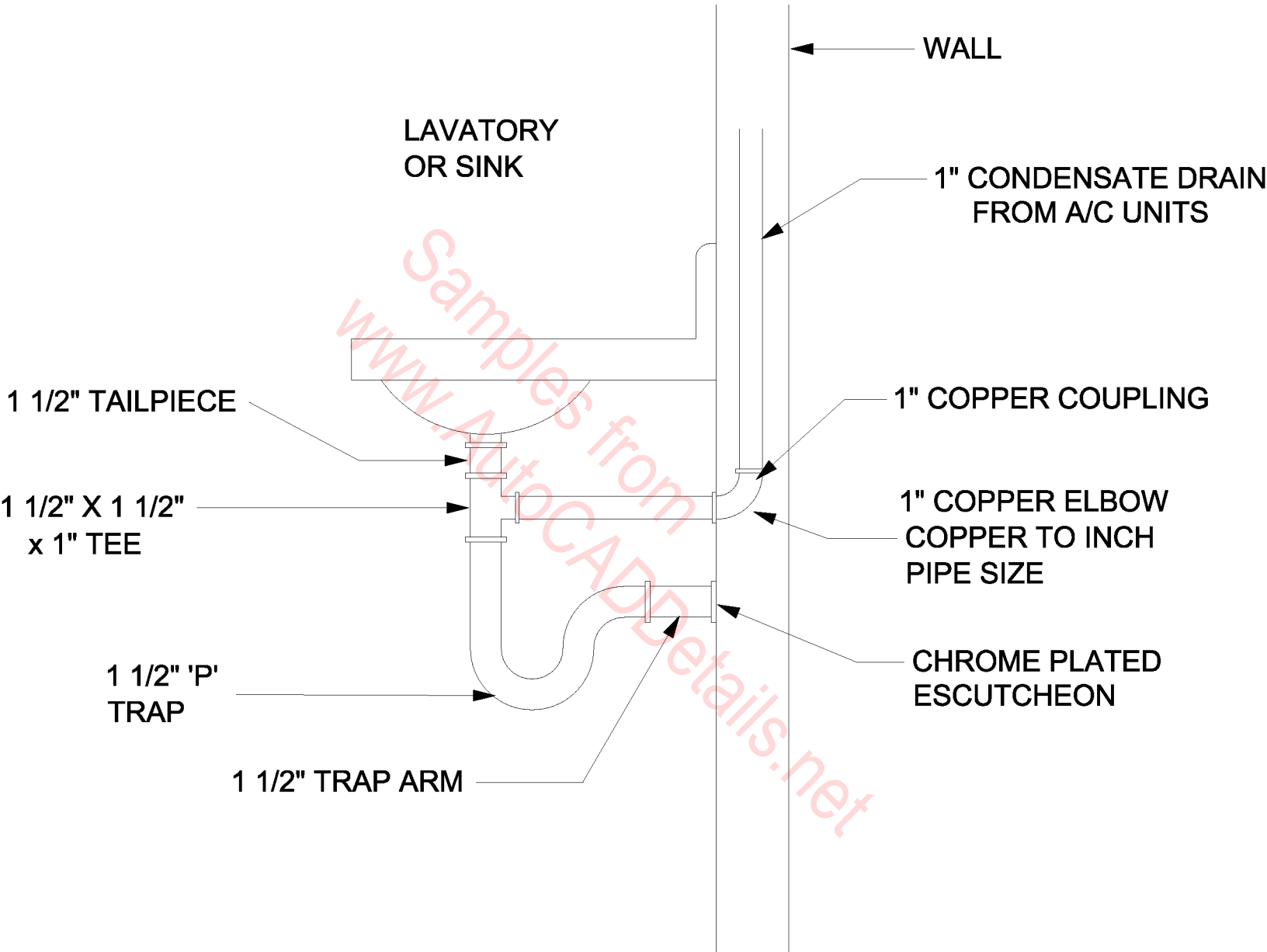

LAVATORY TAILPIECE DETAIL

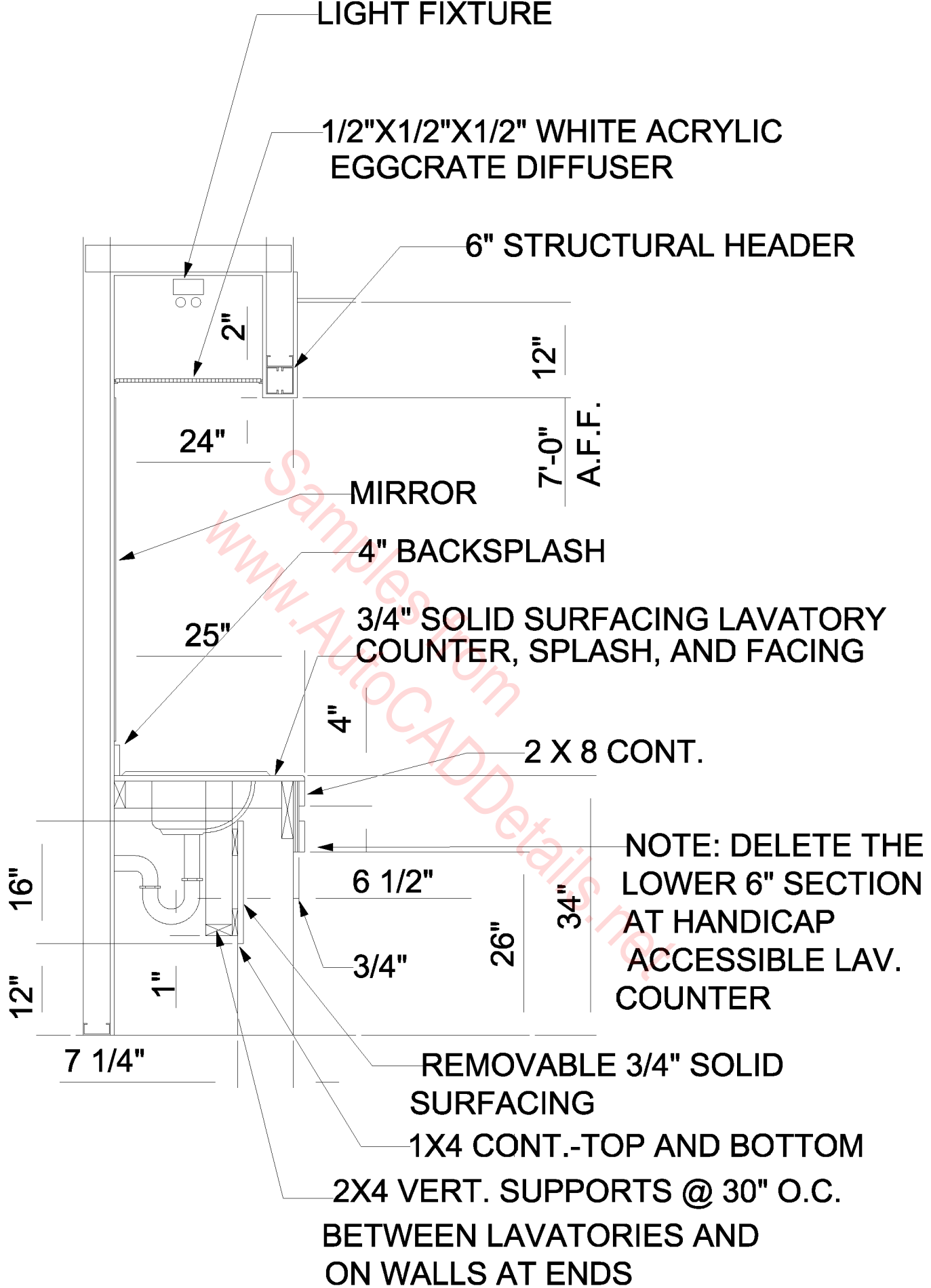

LAVATORY W/RECESSED LIGHT

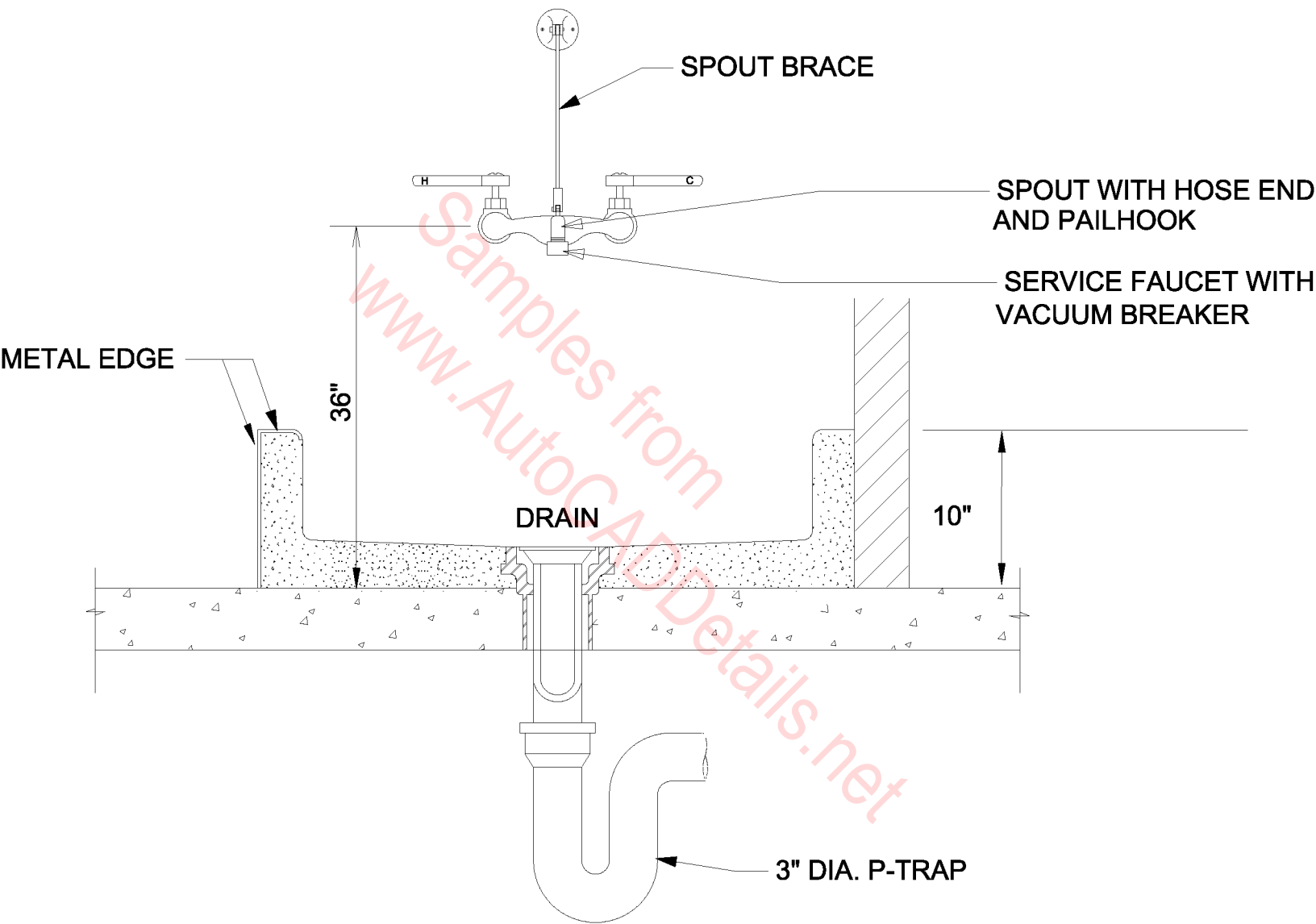

MOP SINK DETAIL

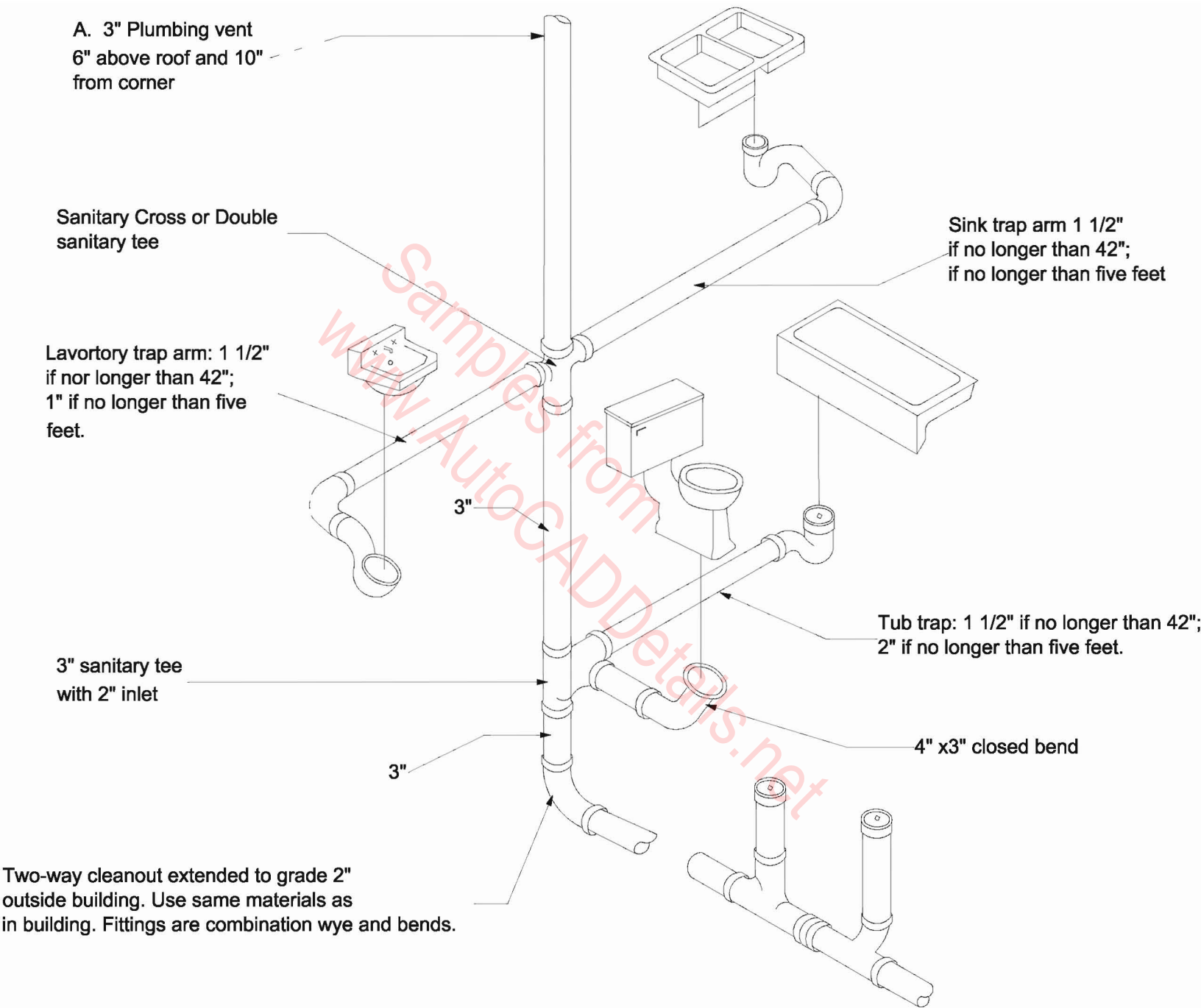

One Bath Plumbing

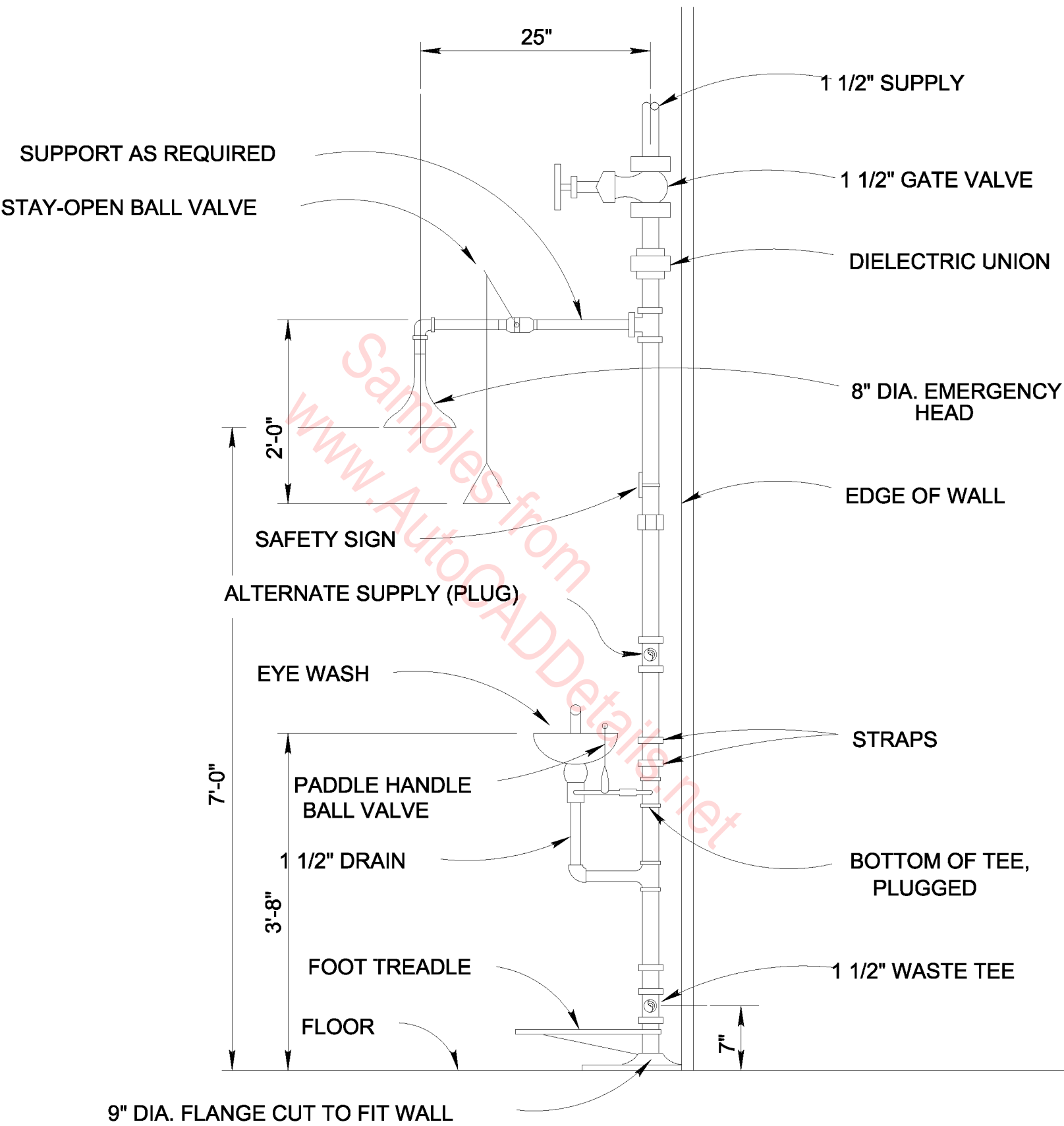

SAFETY SHOWER - EYE WASH DETAIL

WALL

TRAP AND PLUMBING
CONCEALED IN WALL

FLOOR

NOTES:

1. INSTALL ACCORDING TO MANUFACTURER'S INSTRUCTIONS.

SEMI-RECESSED DRINKING WATER COOLER

*Samples from
www.AutoCADDetails.net*

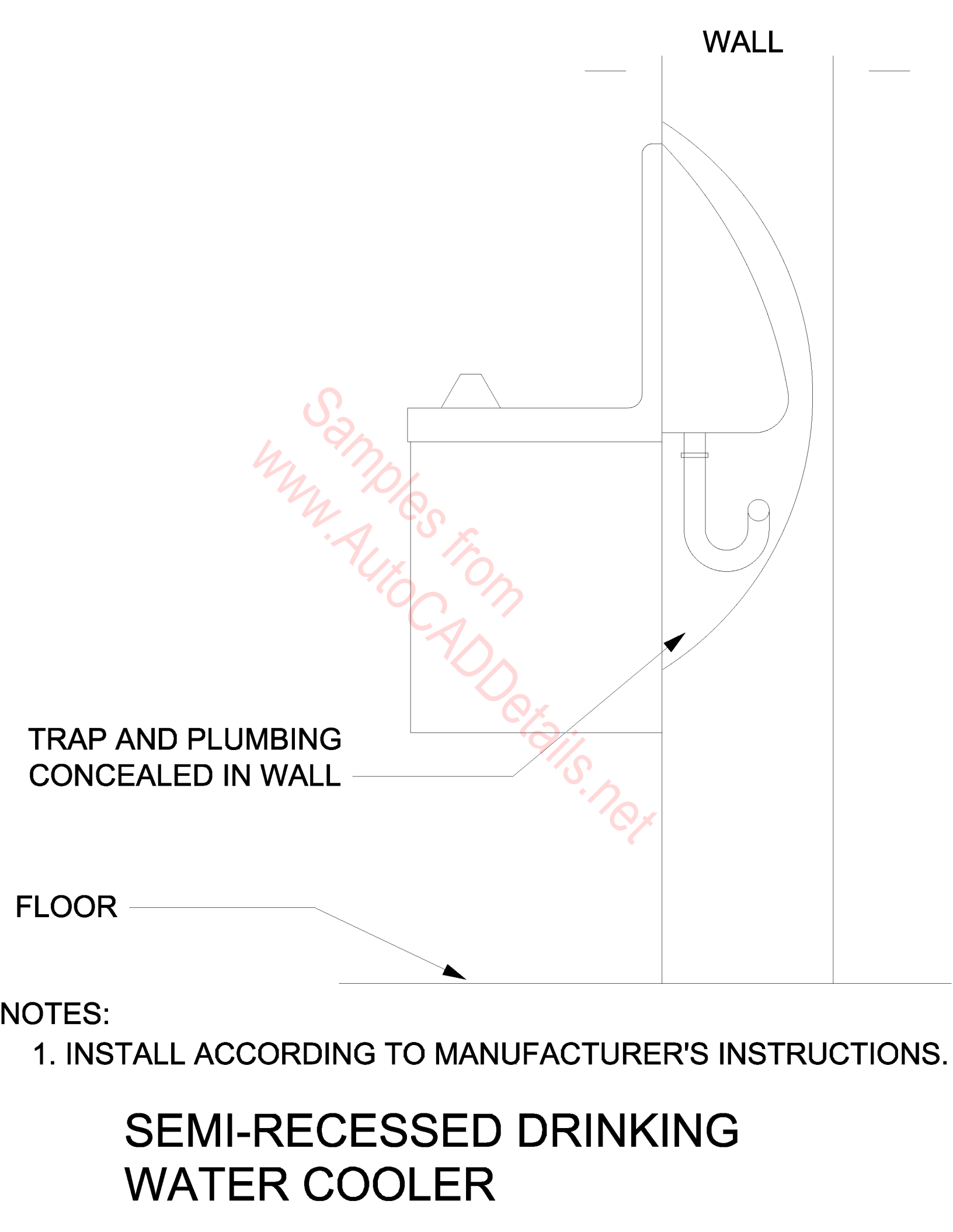

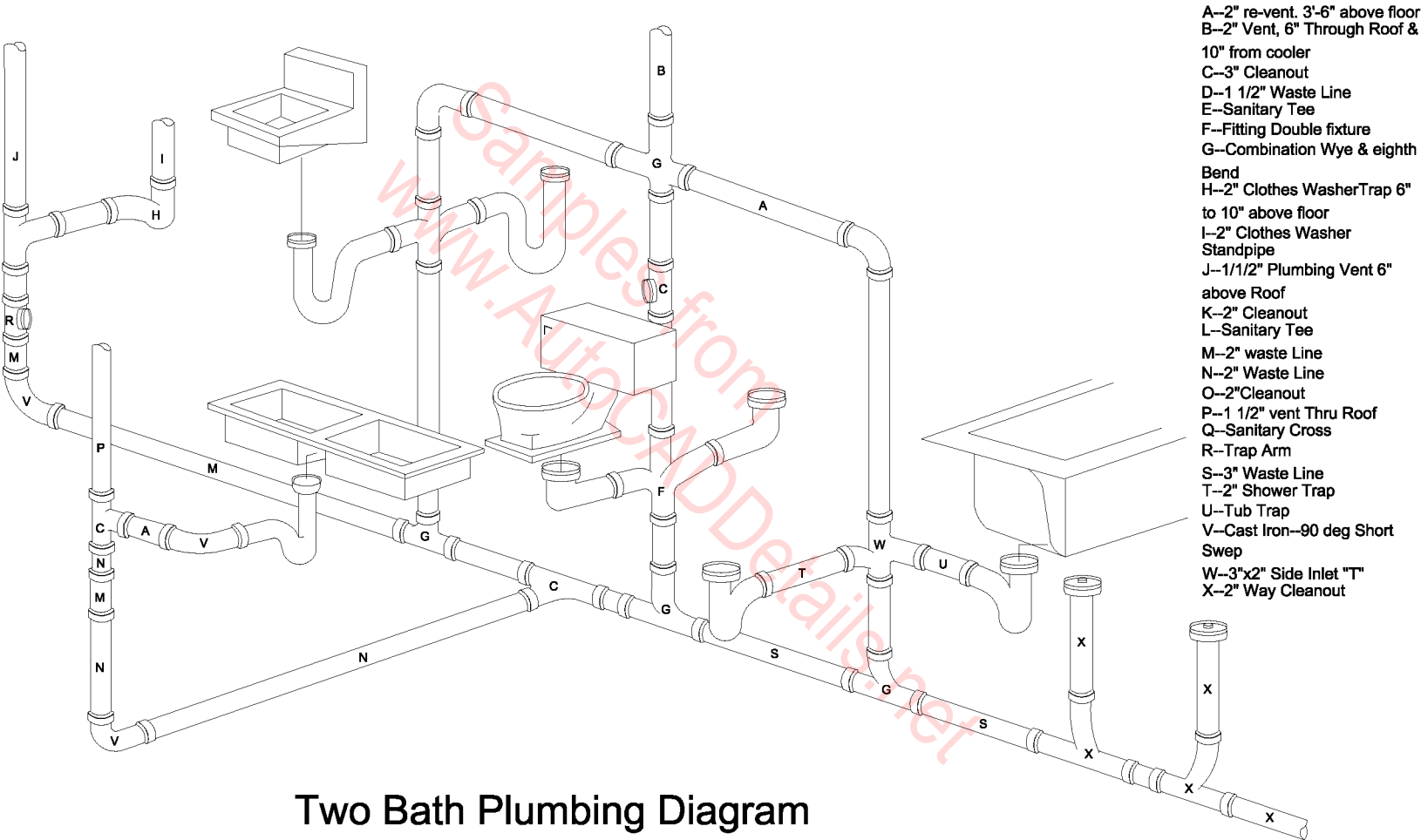

Two Bath Plumbing Diagram

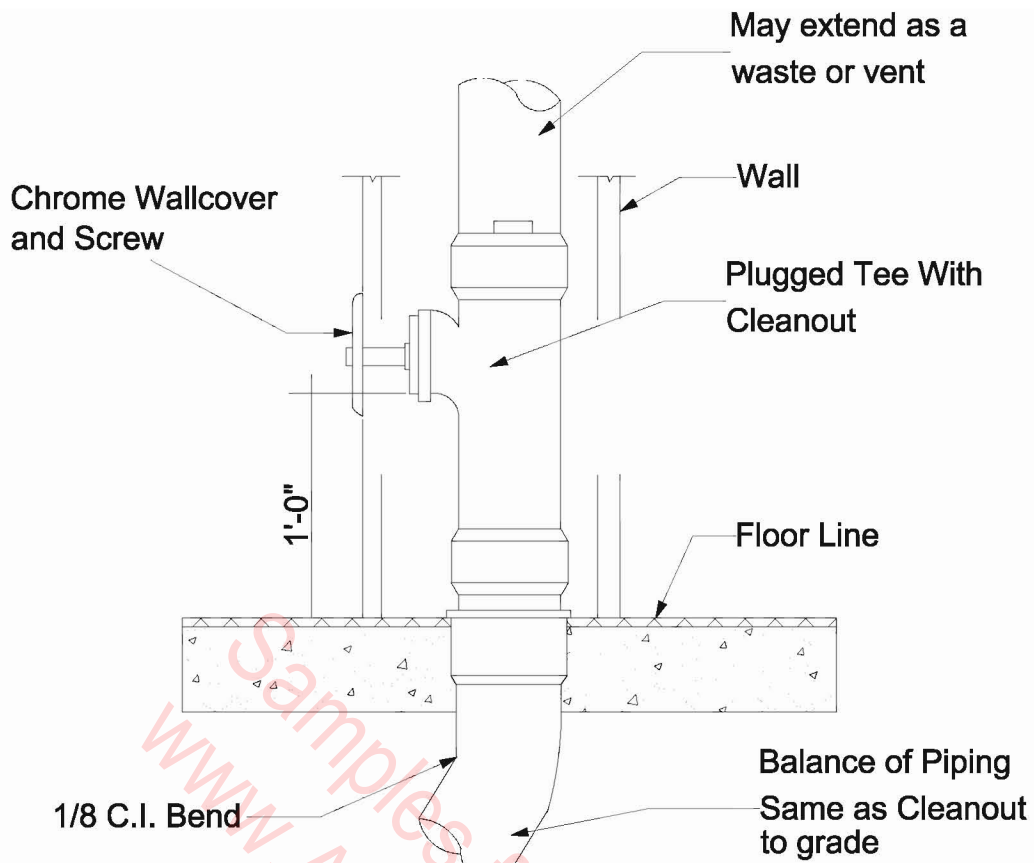

Wall Cleanout Diagram (WCO)

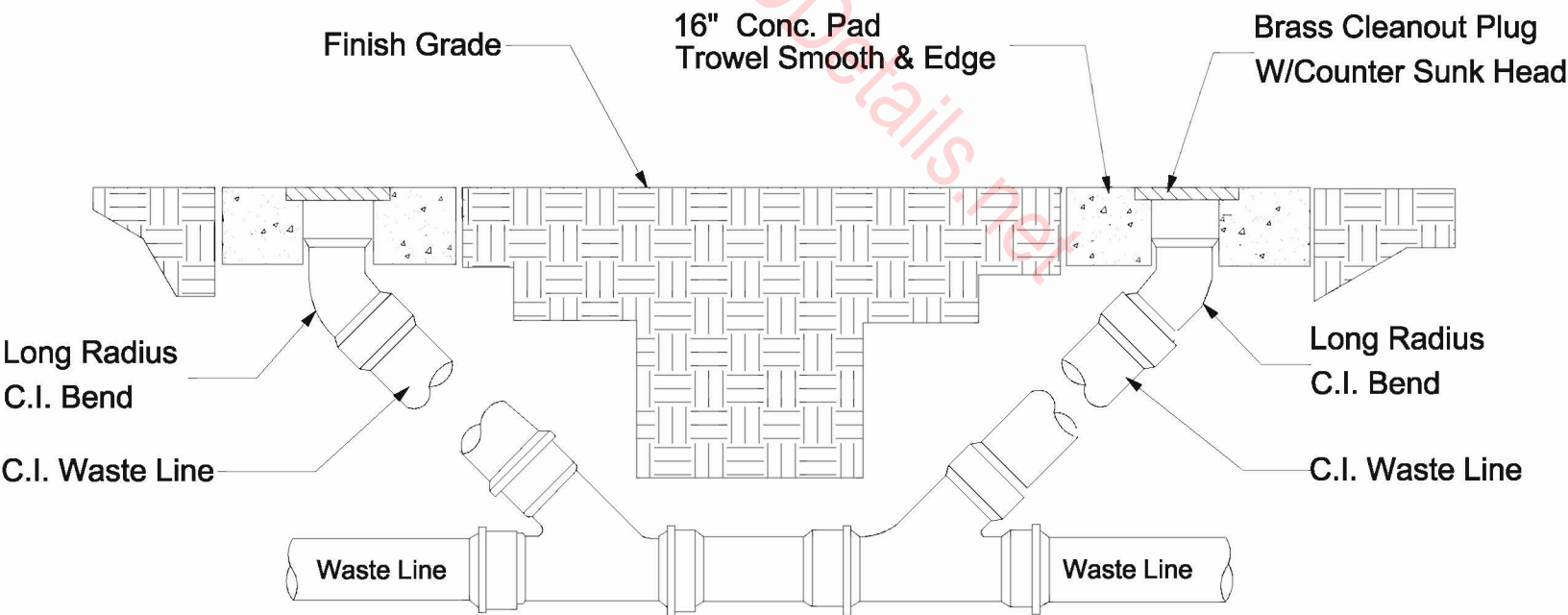

Two-Way Cleanout To Grade Diagram (COTG)

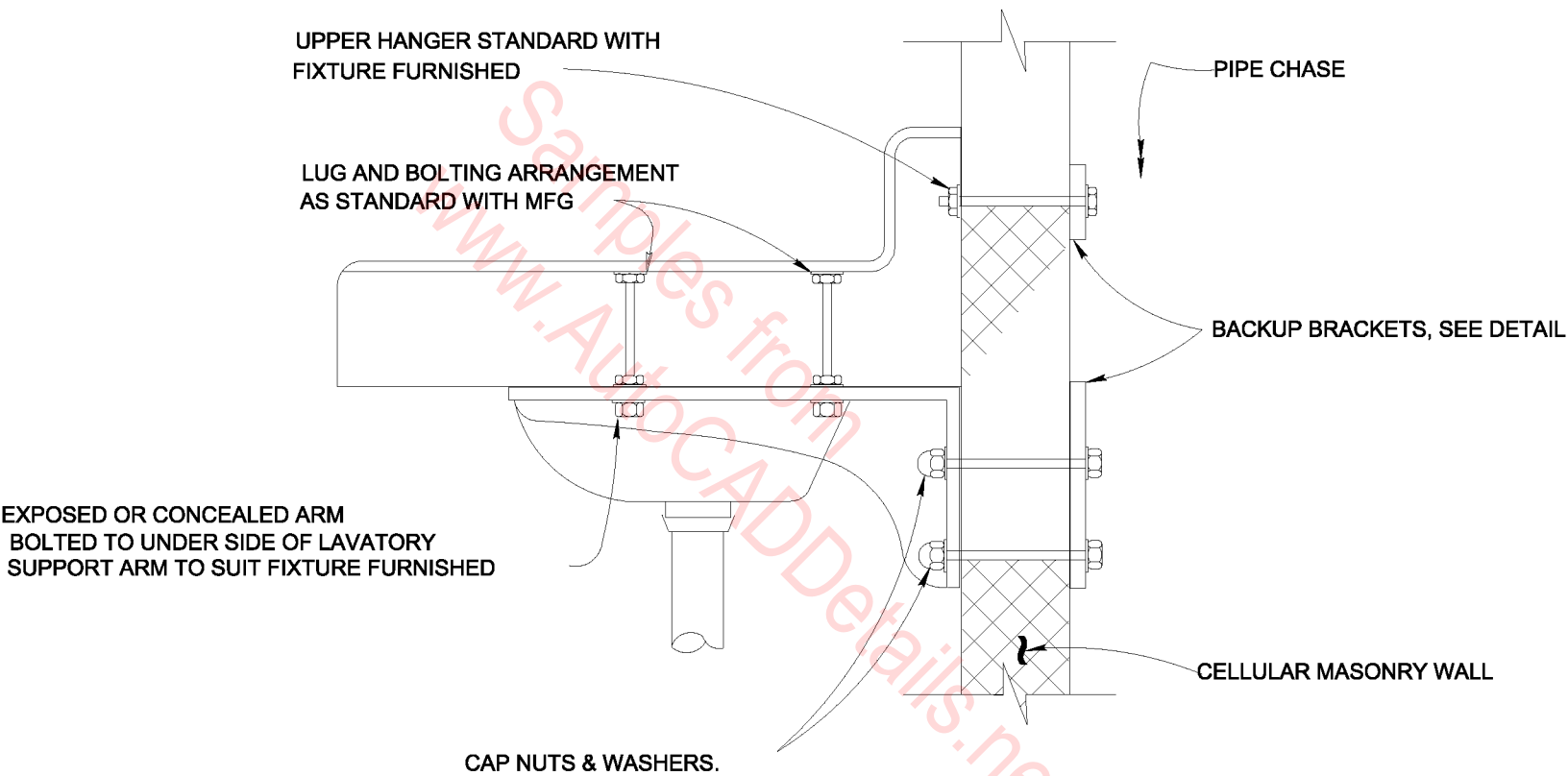

**TYPICAL MOUNTING FOR P-6 CAST IRON
LAVATORY ON CELLULAR MASONRY WALL PIPE CHASE**

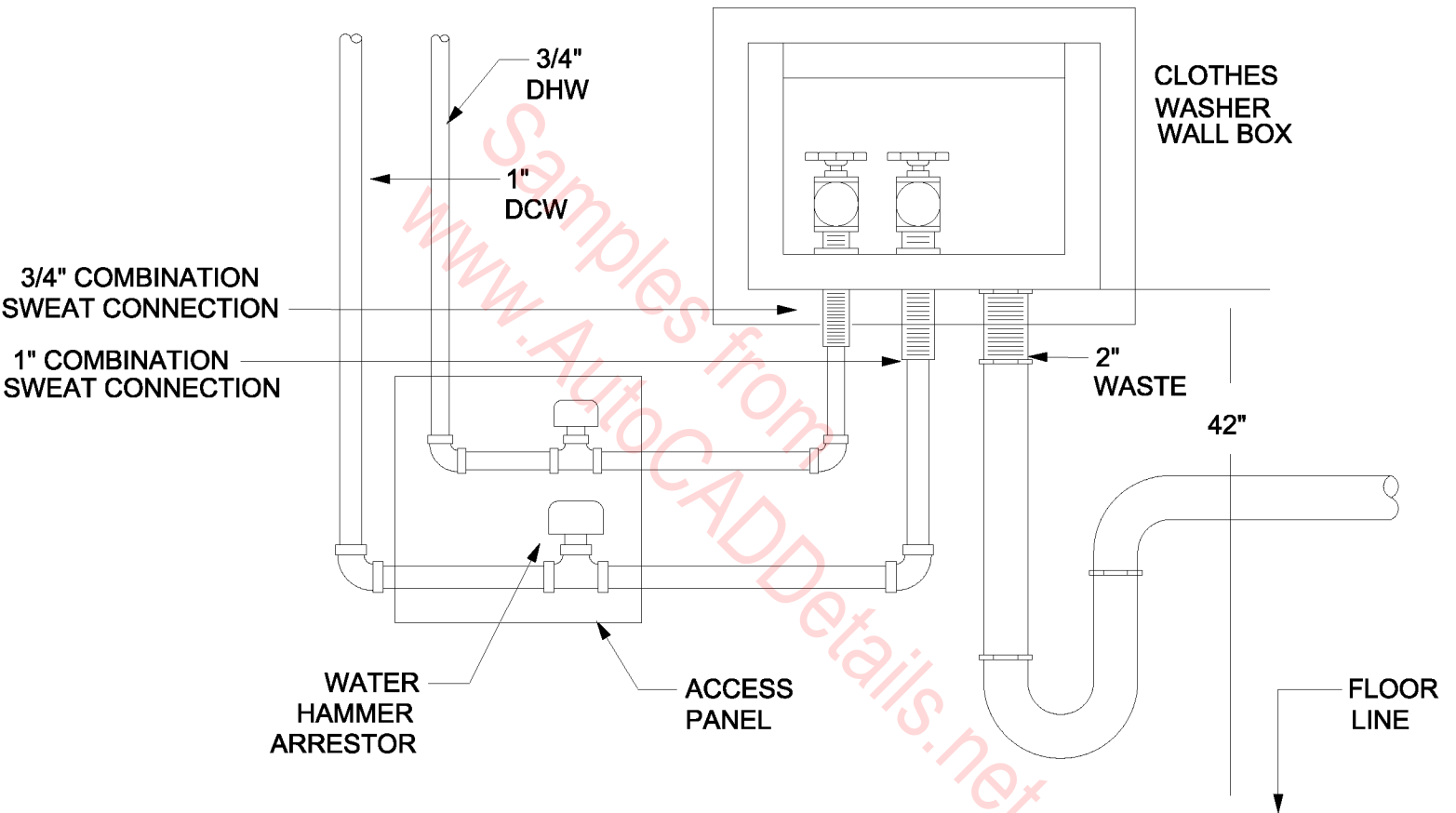

UTILITY WALL BOX FOR CLOTHES WASHER

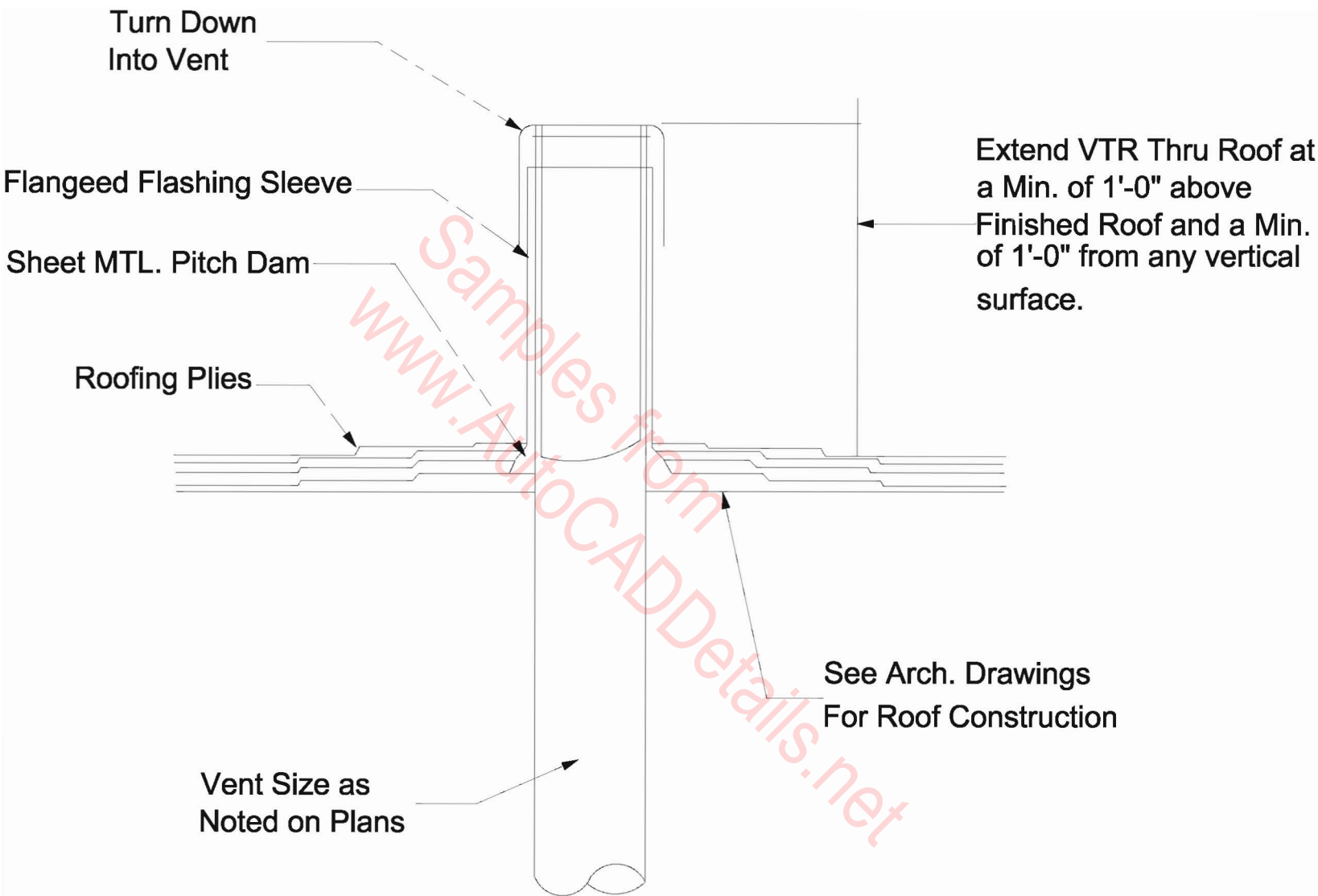

Vent Thru Roof Diagram

TRAP AND PLUMBING
CONCEALED IN
CABINET

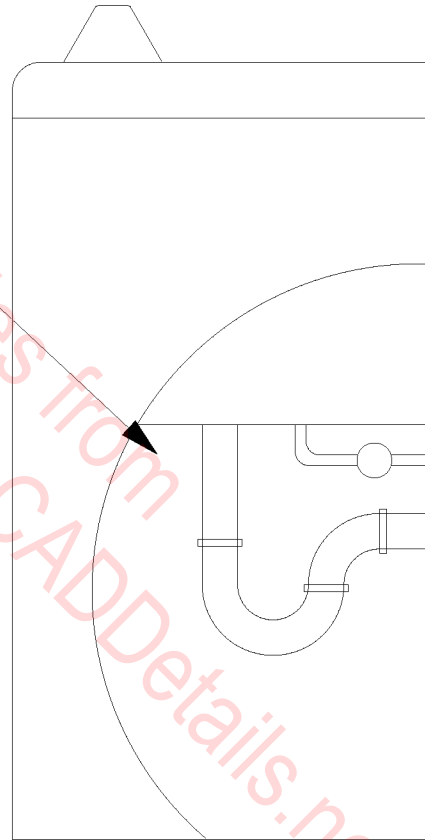

FLOOR

NOTES:

1. INSTALL ACCORDING TO MANUFACTURER'S INSTRUCTIONS.

WALL-HUNG DRINKING WATER COOLER

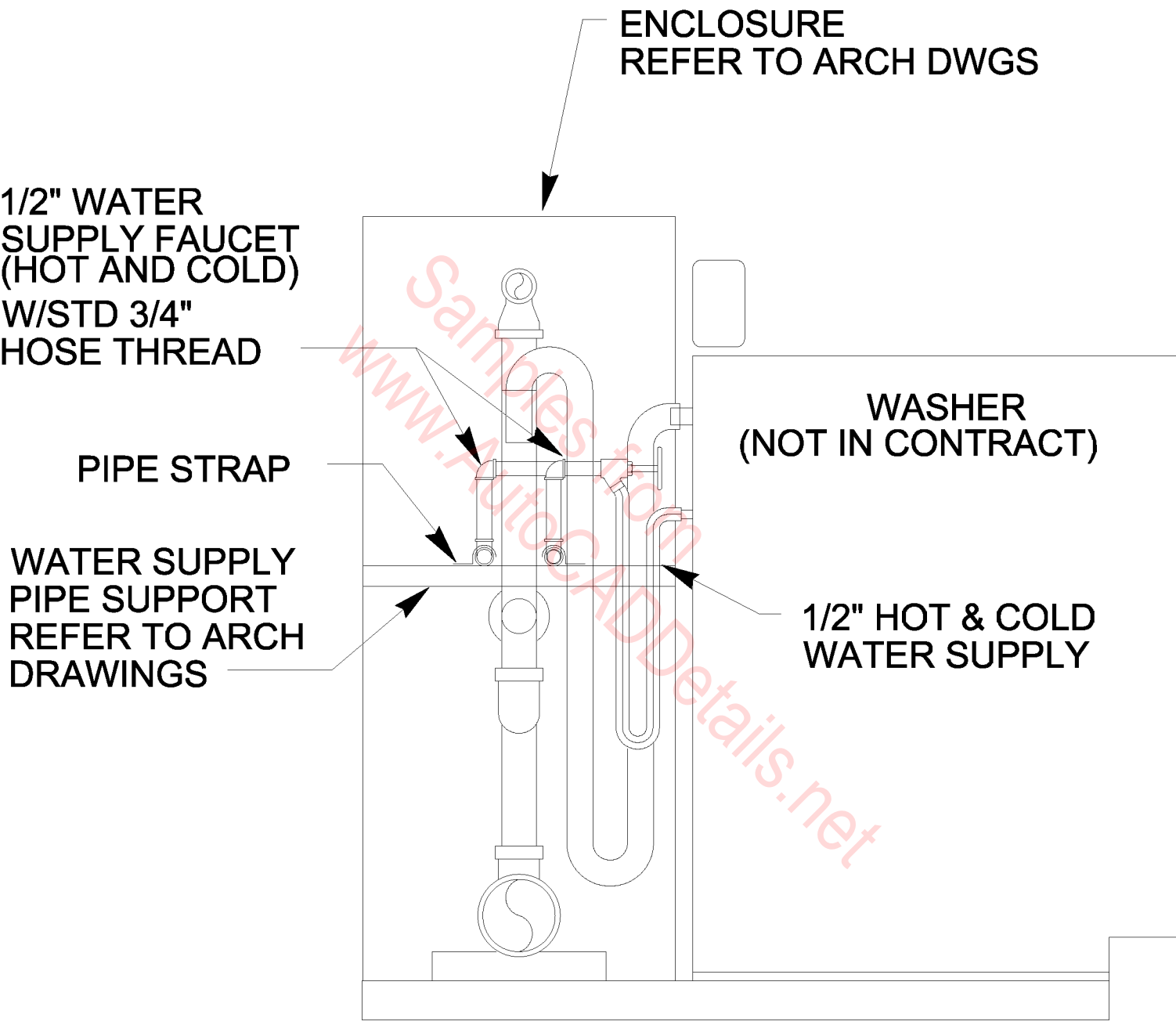

WASHER WATER CONNECTION DETAIL

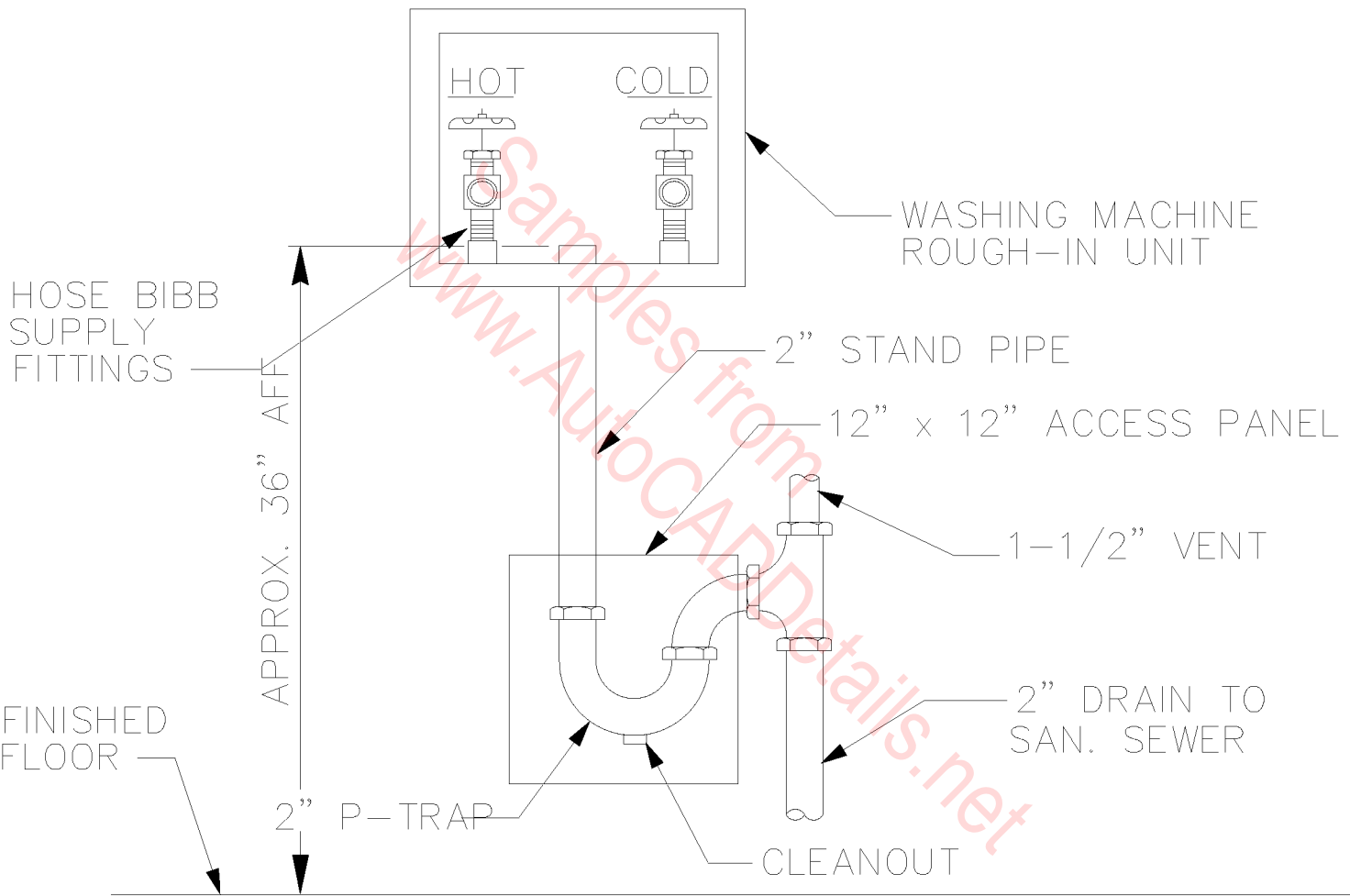

WASHING MACHINE HOOK-UP DETAIL

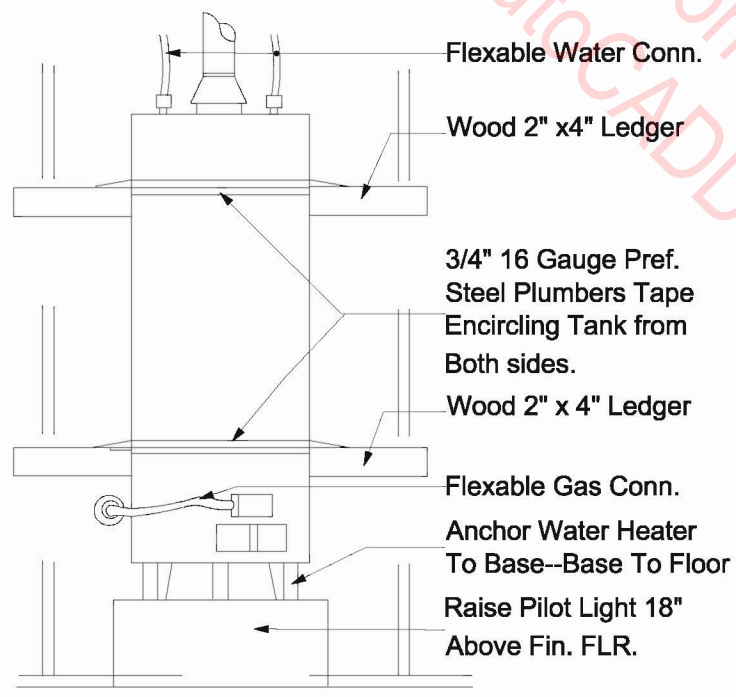
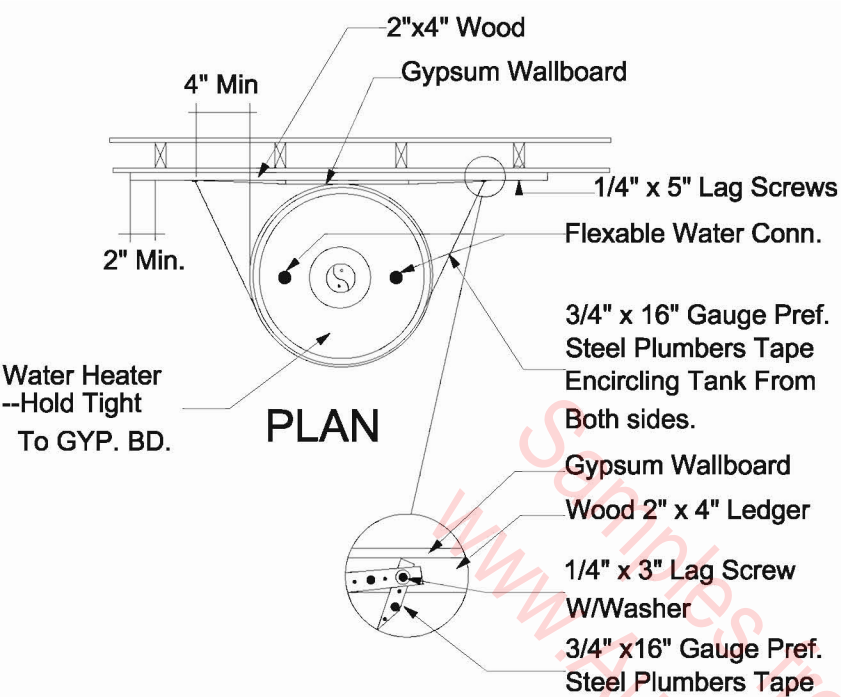

ELEVATION

Water Heater Support

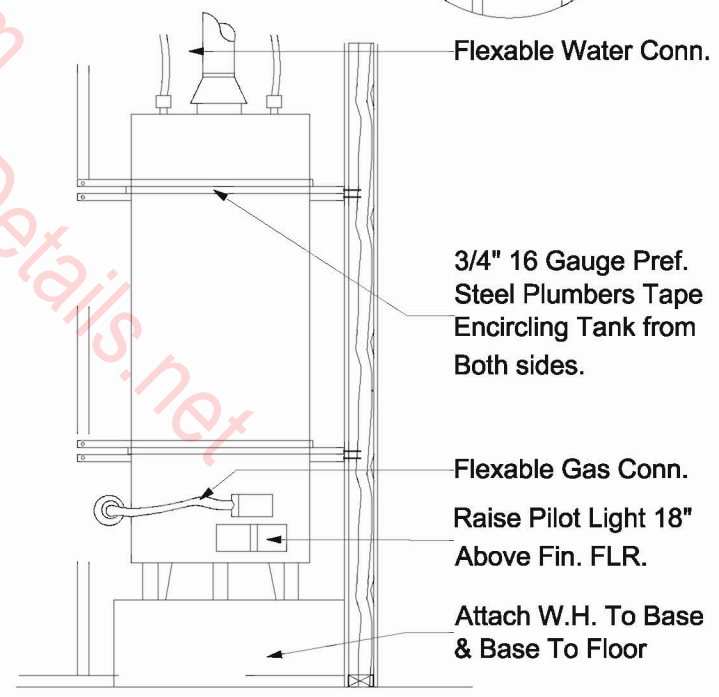
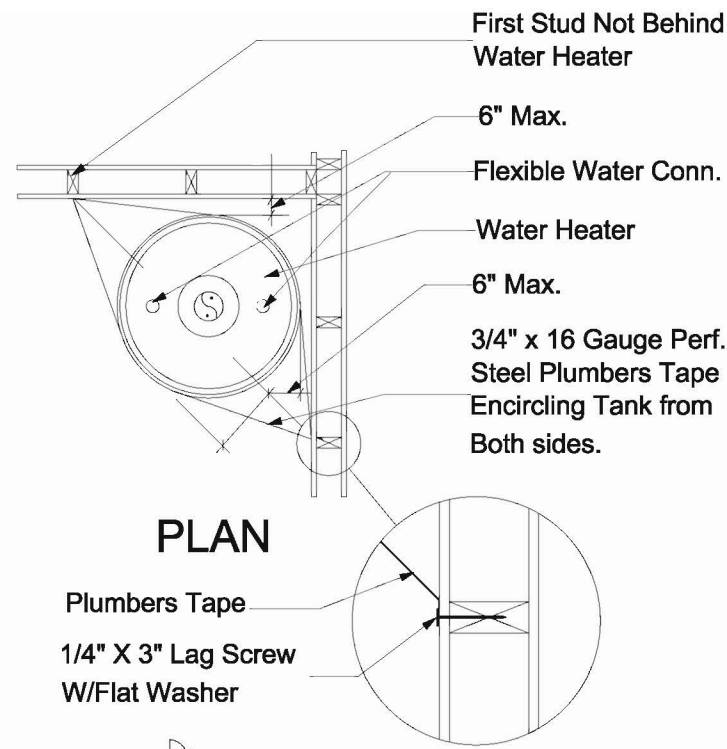

ELEVATION

Corner Heater Supports